

ECV Technical Data

High Lift Pallet Truck

ECV 10

ECV 10C

ECV 10iC





Features				STILL	STILL	STILL
1.1	Manufacturer			ECV 10	ECV 10C	ECV 10iC
1.2	Manufacturer's model designation			Electric	Electric	Electric
1.3	Drive			Pedestrian truck	Pedestrian truck	Pedestrian truck
1.4	Operation			1000	1000	1000 (1200) ¹
1.5	Capacity/load	Q	kg	600	600	600
1.6	Load centre distance	c	mm	815	805	805
1.8	Load distance	x	mm	1233	1131	1265
1.9	Wheel base	y	mm	605	462	520
2.1	Service weight			598/1007	534/928	-
2.2	Axle load, laden	drive end/load end		kg	451/154	370/150
2.3	Axle load, unladen	drive end/load end		kg	605	533/380
3.1	Tyres			Polyurethane	Polyurethane	Polyurethane
3.2	Tyre size	drive end		mm	Ø 210 x 70	Ø 210 x 70
3.3	Tyre size	load end		mm	Ø 80 x 60	Ø 80 x 60
3.5	Number of wheels (x = driven)	drive end/load end			1x1/4	1x1/4
3.6	Track width	b ₁₀ /b ₁₁	mm	533/370	533/380	533/380
4.2	Height of mast when lowered	h ₁	mm	2070	1940	1940
4.3	Free lift	h ₂	mm	0	1505	1480
4.4	Lift	h ₃	mm	2927	1517	1513
4.5	Height of mast when raised	h ₄	mm	3487	1955	2090
4.6	Initial lift	h ₅	mm	-	-	115
4.9	Tiller handle height in driving position	min./max.	h ₁₄	mm	800/1250	800/1250
4.15	Fork height, lowered	h ₁₃	mm	88	88	88
4.19	Total length	l ₁	mm	1740	1615	1750
4.20	Length including fork backs	l ₂	mm	590	465	600
4.21	Overall width	b ₁	mm	800	800	796
4.22	Fork dimensions	DIN ISO 2331	s/e/l	mm	60/170/1150	60/170/1150
4.24	Fork carriage width	b ₃	mm	680	680	680
4.25	Overall fork width	b ₅	mm	570	550	560
4.32	Ground clearance, centre of wheel base	m ₂	mm	28	28	26
4.34	Working aisle width with pallet 800 x 1200 lengthways	A _{st}	mm	2150	2100	2260
4.35	Turning radius	W _a	mm	1399	1337	1500
5.1	Driving speed	laden/unladen	km/h	4.5/4.8	4.0/4.5	4.0/4.5
5.2	Lifting speed	laden/unladen	m/s	0.12/0.22	0.10/0.17	0.10/0.14
5.3	Lowering speed	laden/unladen	m/s	0.20/0.13	0.20/0.13	0.20/0.13
5.8	Max. gradeability	laden/unladen	%	5/15	5/15	5/15
5.10	Service brake			Electromagnetic	Electromagnetic	Electromagnetic
6.1	Drive motor, rating S2 = 60 min			kW	0.65	0.65
6.2	Lift motor, rating at S3 = 15%			kW	2.2	2.2
6.3	Battery according to DIN 43531/35/36 A, B, C, no			No	No	No
6.4	Battery voltage/rated capacity K _s			V/Ah	2x 12/125	2x 12/85
6.5	Battery weight			kg	2x 33	2x 25
6.6	Energy consumption according to VDI cycle			kWh/h	0.414	0.379
8.1	Transmission control			DC control	DC control	DC control
8.4	Noise level (at operator's ear)			dB(A)	74	74

¹ Load capacity with initial lift employed

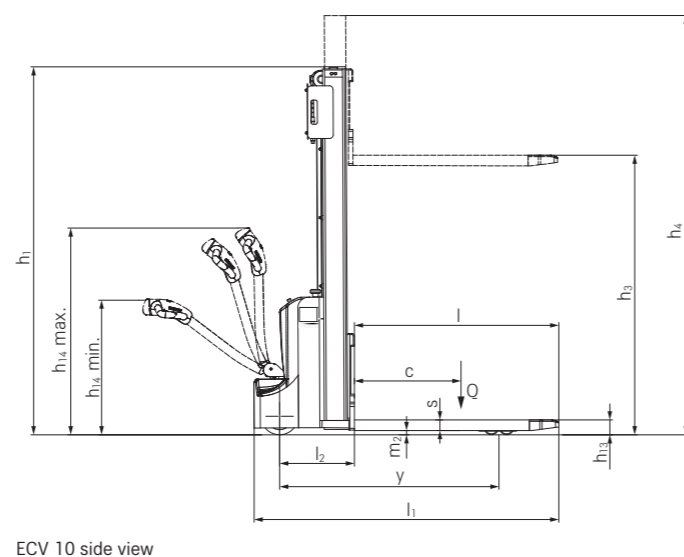
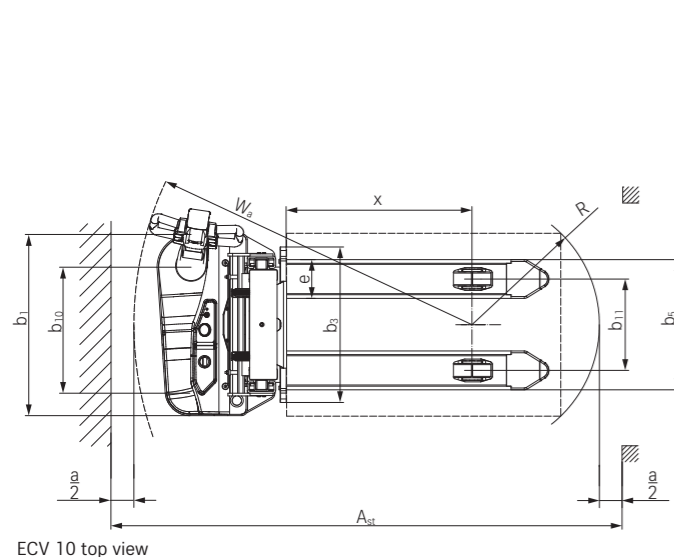

Mast Tables

		Telescopic mast					
		ECV 10					
Height	h ₁	mm	1672	1772	1872	2022	2172
Overall height with activated free lift (h ₃ = 150 mm)	h ₁ '	mm	1747	1847	1947	2097	2247
Free lift	h ₂	mm	150	150	150	150	150
Lift	h ₃	mm	2227	2427	2627	2927	3227
Height, mast extended	h ₄	mm	2787	2987	3187	3487	3787
		Mono mast					
		ECV 10 C		ECV 10i C			
Height	h ₁	mm	1940	2290	1940	2290	
Overall height with activated free lift (h ₃ = 150 mm)	h ₁ '	mm	1940	2290	1940	2290	
Free lift	h ₂	mm	1505	1855	1480	1830	
Lift	h ₃	mm	1517	1867	1513	1863	
Height, mast extended	h ₄	mm	1955	2305	2011	2361	

ECV 10C / ECV 10iC High Lift Pallet Truck
 Technical Drawings

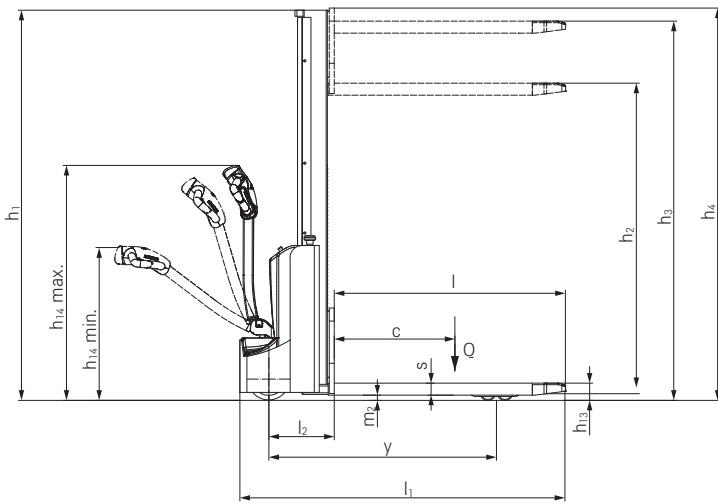

ECV 10 C side view

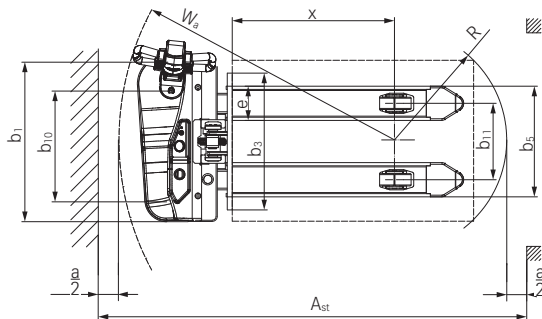

ECV 10 C top view

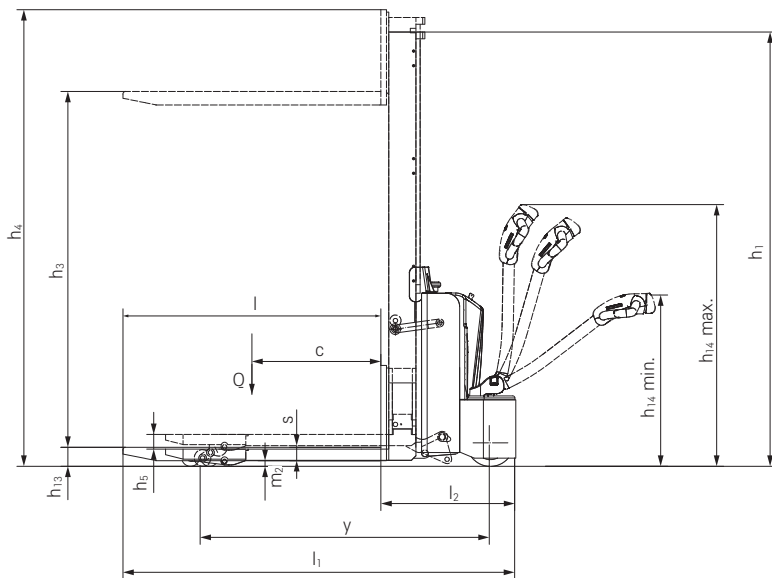

ECV 10iC side view

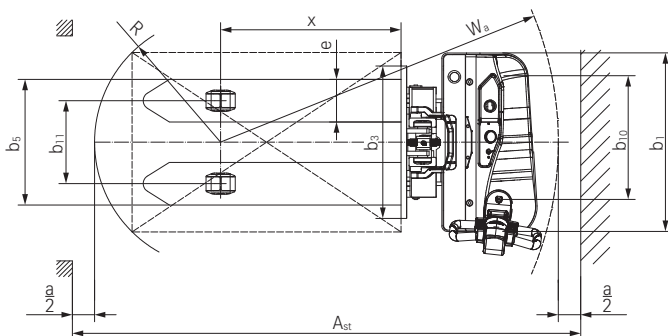

ECV 10iC top view

ECV High Lift Pallet Truck Detailed Photos



Fatigue-free operation thanks to easy-grip tiller for both left- and right-handed operators



Easily cross thresholds thanks to the optional initial lift for more ground clearance on the ECV 10iC, whilst maintaining safety on the move thanks to lift-height-dependent speed reduction



The built-in charger ensures maximum availability and enables decentralised charging, with clear visibility of battery status and operating hours thanks to the LED display



Low service weight enables use on mezzanine floors or in freight lifts and low frame construction for maximum operator safety



Lift heights of up to 3,227 mm facilitate a high degree of storage capacity



Compact front end dimensions for maximum manoeuvrability even in the narrowest working aisles with excellent stability thanks to the 4-wheel undercarriage



Rounded fork tips for fast and precise positioning into the pallets



Increased productivity thanks to the optimum view of the forks during stacking in racks

ECV High Lift Pallet Truck Lifting Made Easy

High turnover performance: Lifting capacity up to 1,000 kg and lift heights up to 3,227 mm

Maximum availability: Long battery life and built-in charger for easy charging

Manoeuvrable and compact: Small front end enables excellent manoeuvrability and usage in narrow aisles



ECV 10

Reaching new heights: With the ECV 10 you can reach a lift height of up to 3,227 mm. Paired with a maximum lifting capacity of up to 1,000 kg, the ECV 10 high lift pallet truck provides ideal support for light and sporadic stacking applications. The compact truck dimensions enable transporting and stacking even in tight working areas and narrow aisles. Two 12 V batteries provide 125 ampere hours for long operating times, and with its built-in charger, the ECV 10 can be recharged at any standard power socket. The LED display shows the current battery charge status and the operating hours, so the operator

always has everything in sight. The ECV 10 also performs well in terms of safety. The wide view between the lift profiles allows for an optimum view of the fork tips. In addition, the lowered design of the vehicle frame protects the feet of operators and third parties. The ECV 10 is also equipped with automatic speed reduction based on lift height, to keep you safe when driving. All functions can be operated with equal ease by left- and right-handed operators thanks to the optimised shape of the tiller.

Flexible down to the tips of the forks: Be it light stacking tasks up to 1,867 mm or used as a mobile workbench

Our most compact high lift pallet truck: Because of the extremely small front end it impresses even in the tightest working areas

Go anywhere: With the optional initial lift on the ECV 10iC variant, slopes and thresholds are easily mastered



ECV 10C / ECV 10iC

Are you looking for a starter truck in the world of pallet stackers? Allow us to introduce the ECV 10C, our most compact high lift pallet truck which can master applications in the narrowest working areas with ease. The mono mast provides the best possible view of the fork tips so the operator can position them accurately into the pallet. The compact ECV 10C is also equipped with automatic lift-height-dependent speed reduction for maximum transport safety. With a mono mast and a maximum lifting capacity of up to 1,000 kg it can be used for a wide range of applications. Whether being used for stacking applications up

to 1,867 mm or to provide ergonomic support as a mobile workbench, the ECV 10C is an all-rounder. The easy-grip tiller for left- and right-handed operators enables precise operation of all of the driving and lifting functions. The ECV 10C also performs well in terms of availability because it always has the necessary amount of power thanks to its built-in charger. The battery can be recharged conveniently and simply at any standard socket. The ECV 10iC version of the compact high lift pallet truck is optionally available with initial lift function for easy negotiation of thresholds, uneven surfaces and ramps.

ECV High Lift Pallet Truck

The 'Simply Efficient' factors: Performance attributes as a measure of economic efficiency



Simply easy

- Handle gradients with ease thanks to the optional initial lift function on the ECV 10iC
- Low service weight enables smooth steering
- Both left- and right-handed users can intuitively operate all of the driving, lifting and lowering functions
- Tandem load rollers provide for smooth driving behaviour on uneven ground
- Low steering forces when manoeuvring relieve the stress on the operator



Simply powerful

- Effective goods handling thanks to a load capacity of up to 1,000 kg
- High degree of storage compression thanks to maximum lift heights of up to 3,227 mm on the ECV 10
- Maintenance-free batteries save precious time



Simply safe

- Optimum stability thanks to four-wheel chassis
- Optimum view of the forks thanks to free view mast or mono mast
- Fatigue-free operation of all driving, lifting, and lowering functions for both left- and right-handed operators

- The low chassis frame protects the feet of operators and third parties in public areas
- Lift height-dependent speed reduction increases safety
- No battery gassing – this protects operators and the environment



Simply flexible

- Compact front end enables use in tight working areas and narrow aisles
- Possible use on mezzanine floors due to low service weight
- The built-in charger allows for flexible and decentralised charging of the forklift truck



Simply connected

- Battery charge display: Battery status is quick and easy to read so batteries can be charged in good time whenever necessary

Equipment Variants



		ECV 10	ECV 10C	ECV 10iC
General	Electric lifting and driving	●	●	●
	High performance 0.65 kW drive motor	●	●	●
	Stable and robust frame design	●	●	●
	Easy-grip tiller for left- and right-handed operators	●	●	●
	LED battery charge display	●	●	●
	Operating hours counter	●	●	●
	Low positioned tiller	●	●	●
	Precise driving behaviour	●	●	●
	Creep speed	●	●	●
	Four-wheel chassis for maximum stability	●	●	●
Mast	Stabilising wheel	●	●	●
	Initial lift	—	—	●
	Various mono masts	—	○	○
	Various telescopic masts	○	—	—
Tyres	Free view mast	●	●	●
	Protective mast screen made from polycarbonate	●	●	●
Safety	Drive wheel tyres, polyurethane	●	●	●
	Load roller tyres, polyurethane, tandem	●	●	●
	Speed reduction based on lift height	●	●	●
Battery	Low chassis frame for maximum operator safety	●	●	●
	Access authorisation with key switch	●	●	●
	Maintenance-free AGM batteries	●	●	●
	Built-in charger	●	●	●
	Protection against unintentional driving when charging is active	●	●	●

● Standard ○ Option — Not available



STILL GmbH
Berzeliusstr. 10
22113 Hamburg
Germany
Tel.: +49 40 73 39 20 00
Fax: +49 40 73 39 20 01
info@still.de

For further information please visit
www.still.eu

STILL is certified in the following areas: Quality management, occupational safety, environmental protection and energy management.



first in intralogistics